

Introduction of APsystems YC1000 Anti-reflux System solutions

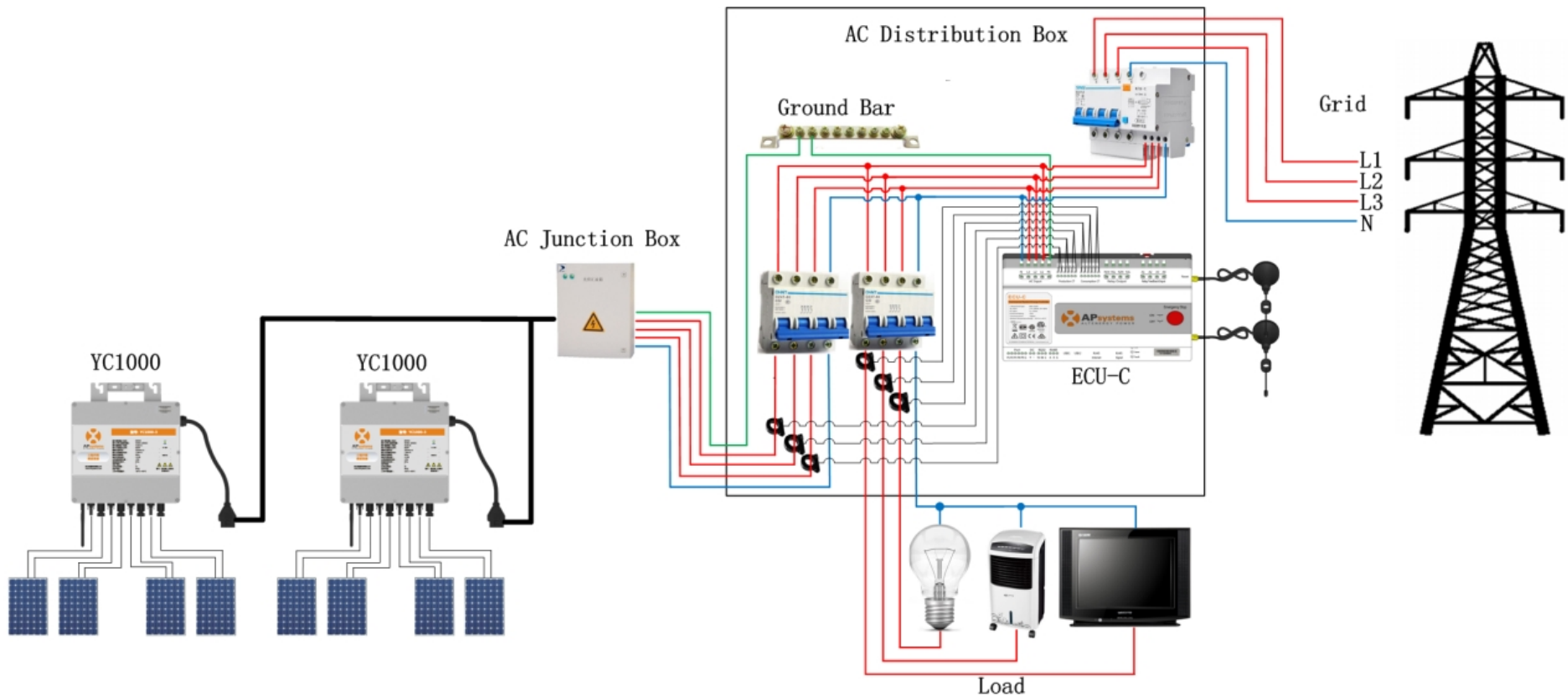

Figure1

APsystems YC1000 Anti-reflux System solutions schematic diagram, please refer to figure 1. To the power generation side and consumption side of PV power generation system, each side has 3 current transformers. ECU-C could measure and compare the power generation and power consumption of each phase by these transformers. To any phase, when the power generation is more than power consumption, then the electric current will flow back into the grid, that's so called reflux. To avoid the reflux, ECU-C will shut all the inverters down at the moment that the reflux occurs. According to the power calculation, under the condition of no reflux, ECU-C will allow to switch on inverters as many as possible to guarantee the maximum power generation.

APsystems

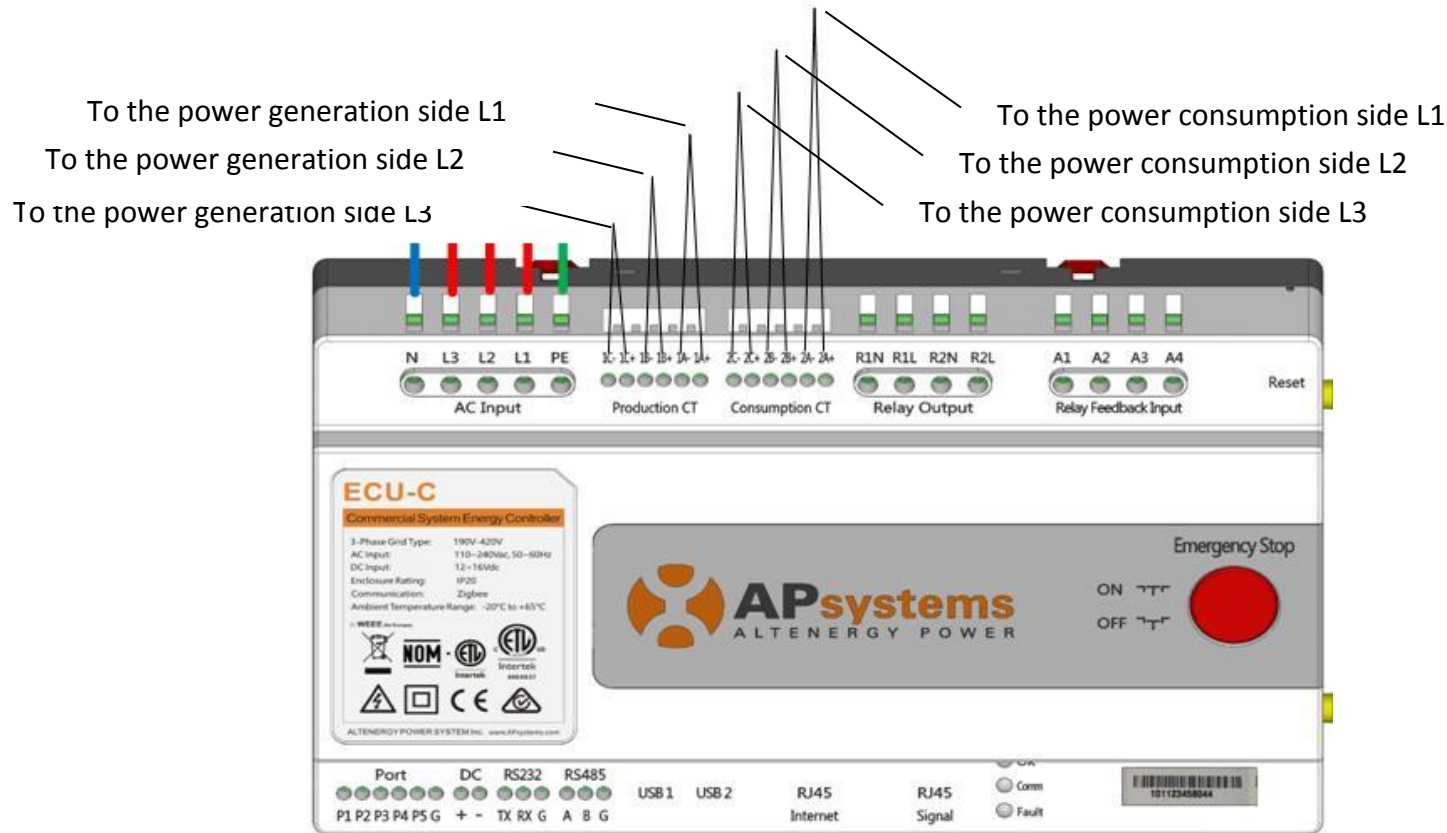

Figure2

ECU-C wiring diagram, please refer to figure2. The AC input side L1, L2, L3, N, PE should be accessed to the grid. At the Production CT, the 3 current transformers should be accessed to the power generation side of PV system. At the Consumption CT, the 3 current transformers should be accessed to the power consumption side of PV system. ECU-C has no requirement for the wiring polarity and coil embeded direction of current transformer. But these following points should be noted: the current transformer between A+ and A- must be accessed to the same grid phase with the AC input side L1; the current transformer between B+ and B- must be accessed to the same grid phase with the AC input side L2; the current transformer between C+ and C- must be accessed to the same grid phase with the AC input side L3.

APsystems