

## Introduction of APsystems YC500/YC600 Anti-backflow System solutions

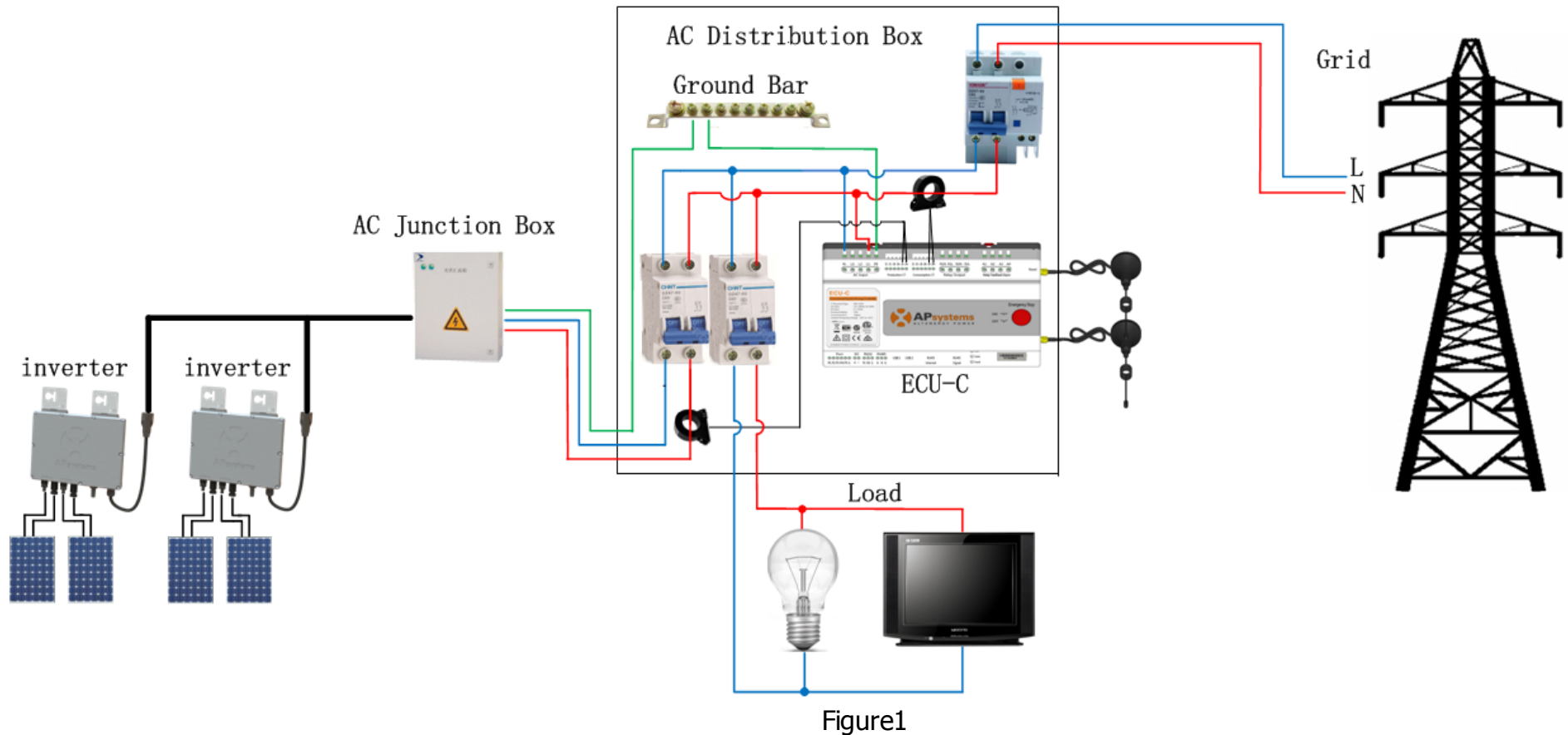

APsystems YC500/YC600 Anti-backflow System solutions schematic diagram, please refer to figure 1. By installing Current Transformer(CT) at the power generation side of PV system and the grid side, ECU-C could measure the generation&grid power and energy. When the grid side current measured by the CT is negative, the electric current will flow back into the grid. Before the backflow occurs or the backflow power is greater than the power limit, ECU-C will shut all the inverters down through communication. According to the power calculation, under the condition of no backflow or backflow power smaller than the power limit, ECU-C will turn on inverters one by one as many as possible to guarantee the maximum power generation.

**APsystems**

Rue des Monts dor ZAC de Follieuses Sud-Les Echets 01700 Miribel, France  
+33-481 65 60 40 | APsystems.com

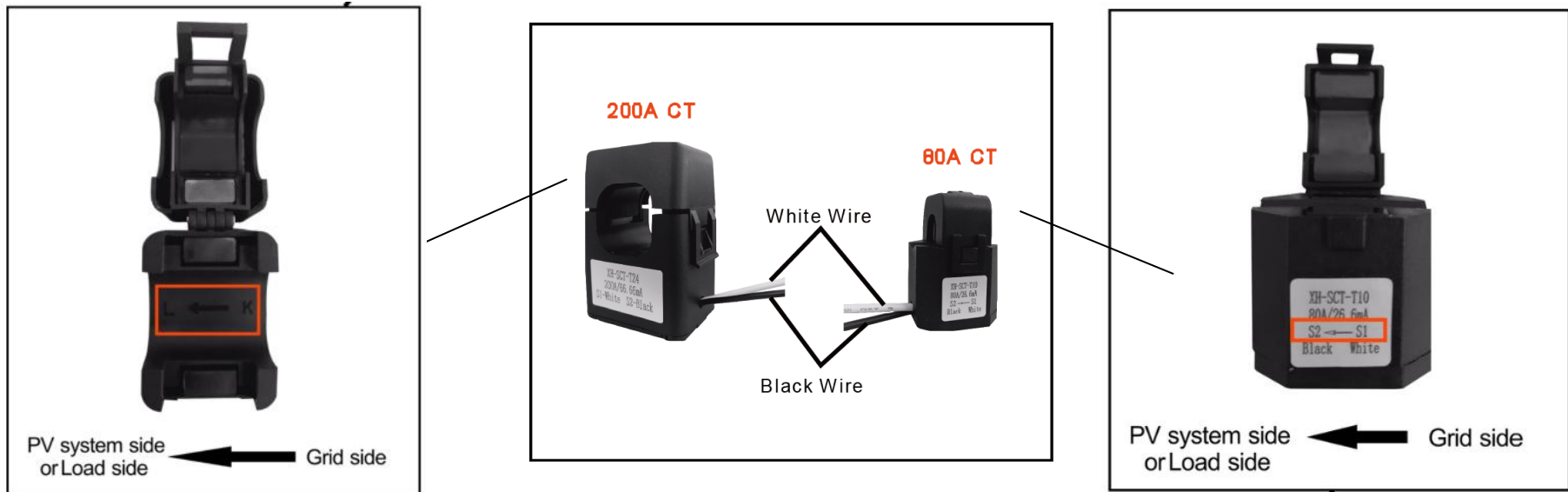
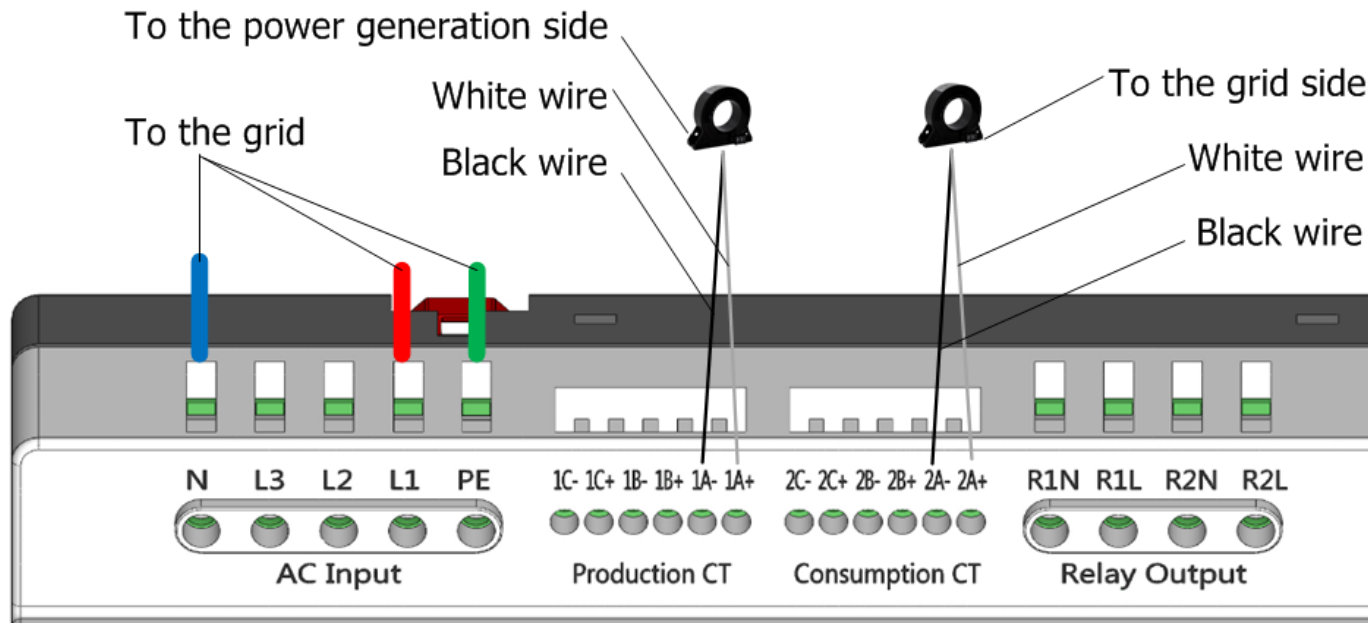

Figure2

ECU-C has requirements for the wiring and coil direction of Current Transformer, please refer to figure2. The AC input side L1, N, PE should be accessed to the grid. The Current Transformer between 1A+ and 1A- should be accessed to the power generation side of PV system. The Current Transformer between 2A+ and 2A- should be accessed to the grid side.

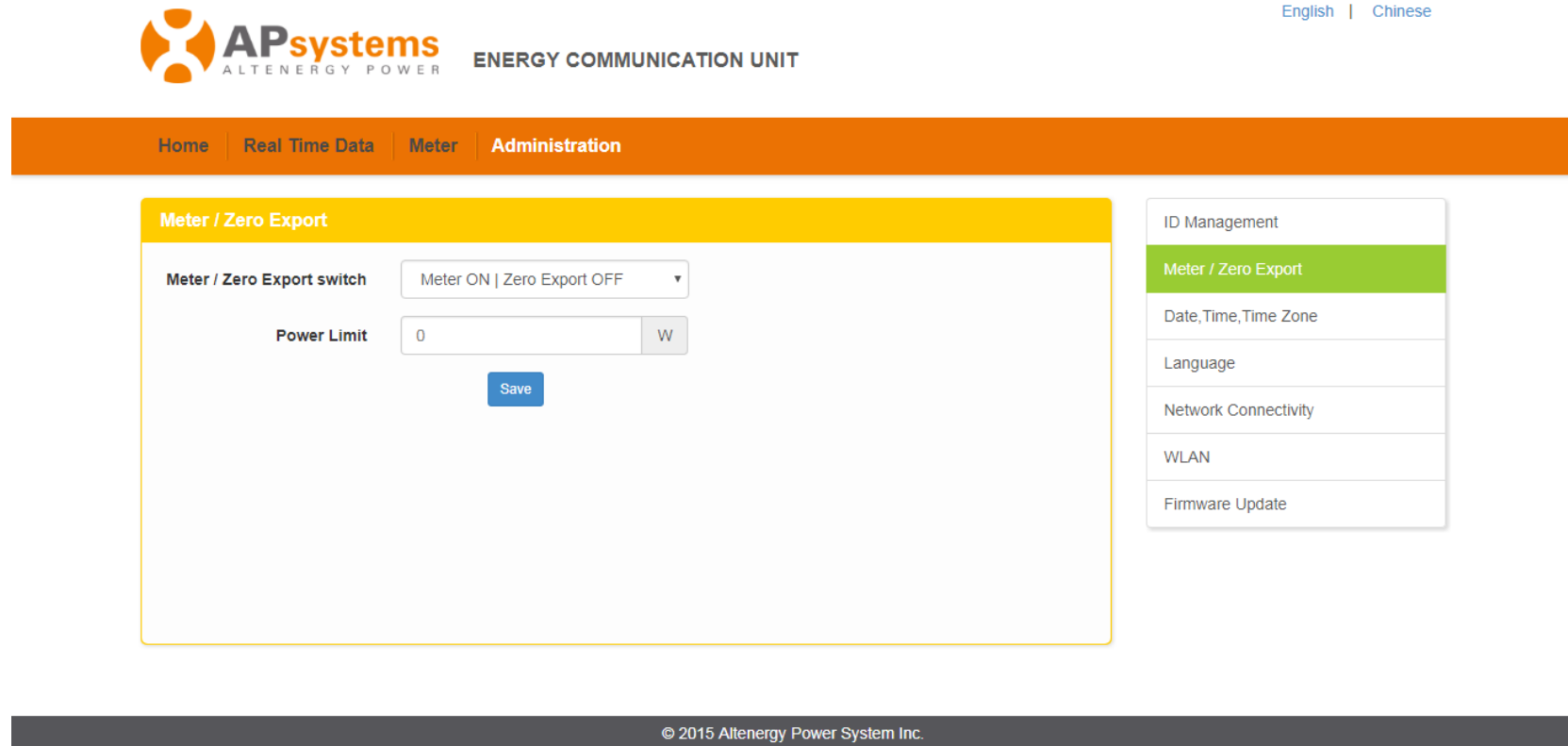

Figure 3

Anti-backflow function can be opened or closed in the ECU-C Local Network Interface like figure 3. In this interface you can also set power limit from 0 to a certain positive number. The power limit means that anti-backflow function works only when the backflow occurs and the backflow power is greater than the power limit.